

PERFORMANCE TEST REPORT

Rendered to:

GLASS CRAFT DOOR CORPORATION

**PRODUCT TYPE: 3' x 8' Single Outswing Hardwood Door
with Side Lites and Half Circle Transom**

Title	Summary of Results
Uniform Load Deflection Test Pressure	+36.2 psf / -45.7 psf
Uniform Load Structural Test Pressure	+54.3 psf / -68.6 psf

This report contains in its entirety:

Cover Page: 1 page
Report Body: 7 pages
Sketch: 1 page
Drawings: 7 pages

Reference should be made to ATI Report No. 64142.01-801-44 for complete test specimen description and data.

PERFORMANCE TEST REPORT

Rendered to:

GLASS CRAFT DOOR CORPORATION
2002 Brittmoore
Houston, Texas 77043-2209

Report No.: 64142.01-801-44
Test Dates: 04/04/06
Through: 07/24/06
Report Date: 08/18/06
Expiration Date: 07/24/10

Project Summary: Architectural Testing, Inc. (ATI) was contracted by Glass Craft Door Corporation to perform testing on a 3' x 8' outswing hardwood door with two side lites and half circle transom. Test specimen description and results are reported herein.

Test Method: The test specimen was evaluated in accordance with the following:

ASTM E 330-02, Test Method for Structural Performance of Exterior Windows, Curtain Walls and Doors by Uniform Static Air Pressure Difference

Test Specimen Description:

Product Type: 3' x 8' Outswing Hardwood Door with Side Lites and Half Circle Transom

Door Description

Overall Size: 68-3/4" wide by 97-3/4" high

Leaf Size: 36" wide by 96" high

Day Light Opening: 21-5/8" wide by 67" high

Glazing Type: Sealed insulating glass comprised of 1/8" thick tempered glass at the exterior and 1/8" thick tempered decorative textured glass at the interior. A 1/2" aluminum spacer system was used providing 3/4" overall thickness.

Glazing Details: Interior glazed with double-sided butyl tape and a nailed-on wood glazing bead secured by 1" long by 0.040" by 0.050" rectangular shank brad nails with a 0.050" by 0.080" head (18 gauge brad nail) 1" from each corner and on 6" spacing thereafter.

Weatherstripping: One five finger vinyl sweep at the bottom of the door leaf. One row of custom shaped foam-filled vinyl weatherstrip at the head and jambs.

Test Specimen Description: (Continued)

Door Description (Continued)

Frame Construction: The doorframe was constructed of 4-5/8" by 1-1/4" hardwood head and jambs, and 3-5/8" by 2-5/8" mullions and included an adjustable extruded aluminum and composite threshold. The head and jambs were kerfed to accept the weatherstripping. The corners were coped and butted and secured with two #8 x 1-1/2" and five #8 x 3" screws at the threshold; and four #8 x 1-1/2" and two #8 x 3" screws at the head. The mullions were attached with five #8 x 3" screws through the head and the threshold.

Leaf Construction: The door leaf was constructed of 1-3/4" thick hardwood and utilized a glued cove and bead joint, reinforced with 1/2" diameter by 4-1/2" long wood dowels. Two dowels were located at the top and middle rail to stile joint, and four dowels were located at the bottom rail to stile joint.

Hardware: One Schlage F-300 Series single-point lockset was located 36" on center from bottom of the leaf and one Schlage deadbolt was located 41-5/8" on center from the bottom of the leaf. Four 4" butt type hinges fastened to each leaf with four #8 x 3" screws. Each hinge was secured to the jamb with two #8 x 3" screws and two #8 x 1" flat head screws. The hinges were located at 9-1/8", 34-1/2", 59-1/2" and 84-3/4" on center from the top of the jamb. Surface bolts were attached to the top and bottom the leaf with four #10 x 1" flat head machine screws with a 1-1/2" long blind nut. Strike plates for the surface bolts were attached to the head with two #8 x 3" screws and to the threshold with two #10 x 3" sheet metal screws.

Drainage: Sloped sill.

Installation: The jambs were secured to a #2 Yellow Pine test buck with two #8 x 3" screws 6" from each corner and on 24" spacing (24 total).

Side Lite Description

Overall Size (2): 1' 3-3/4" wide by 8' 4-3/4" high

Panel Size (2): 1' 2" wide by 8' high

Day Light Opening (2): 10" wide by 5' 7" high

Glazing Type: Sealed insulating glass comprised of 1/8" thick tempered glass at the exterior and 1/8" thick tempered decorative textured glass at the interior. A 1/2" aluminum spacer system was used providing 3/4" overall thickness.

Glazing Details: Interior glazed with double-sided butyl tape and a wood glazing bead fastened with 1" long by 0.040" by 0.050" rectangular shank brad nails with a 0.050" by 0.080" head (18 gauge brad nail) 1" from each corner and on 6" spacing.

Test Specimen Description: (Continued)

Side Lite Description (Continued)

Weatherstripping: None

Panel Construction: The panel was constructed of 1-3/4" thick hardwood and utilized a glued cove and bead joint, reinforced with #8 x 3" screws. Two screws were located at the stile to top rail and stile to lock rail joints. Four screws were located at the stile to bottom rail joints. The side lite was secured to the mullions with eight #8 x 3" screws, 5" from the ends of the mullion and on 12" spacing. The side lite was secured to the frame with eight #8 x 3" screws, 5" from the ends of the jamb and on 12" spacing. Additional fastening was provided by 1/2" quarter round trim fastened by 1-1/4" long by 0.040" by 0.050" rectangular shank brad nails with a 0.050" by 0.080" head (18 gauge brad nail) 1" from each corner and on 6" spacing.

Transom Description

Overall Size: 74-1/8" wide by 37-5/8" high

Panel Size: 72-3/8" wide by 36" high

Day Light Opening: 67-3/4" wide by 31-3/8" high

Glazing Type: Sealed insulating glass comprised of 1/8" thick tempered glass at the exterior and 1/8" thick tempered decorative textured glass at the interior. A 1/2" aluminum spacer system was used providing 3/4" overall thickness.

Glazing Details: Interior glazed with double-sided butyl tape and a wood glazing bead fastened with 1" long by 0.040" by 0.050" rectangular shank brad nails with a 0.050" by 0.080" head (18 gauge brad nail) 1" from each corner and on 6" spacing.

Weatherstripping: None

Frame Construction: The frame was constructed of 4-1/2" by 3/4" hardwood. The corners were secured with two #8 x 3" wood screws.

Panel Construction: The panel was constructed of 1-3/4" thick laminated hardwood and utilized a glued cove and bead joint. Two #8 x 3" screws were located at each stile to rail joint. The panel was secured to the transom frame with seven #8 x 3" screws 3" from each corner and on 18" spacing around the arch and three #8 x 3" screws 3" from each corner and in the center across the sill and with 1/2" quarter round trim fastened by 1-1/4" long by 0.040" by 0.050" rectangular shank brad nails with a 0.050" by 0.080" head brad nails (18 gauge brad nail) 1" from each corner and on 6" spacing. The transom was attached to the head of the door with six #8 x 1-1/2" screws one 3" from each corner of the head/sill and on 13" spacing across the head/sill.

Test Specimen Description: (Continued)

Transom Description (Continued)

Installation: The jambs were secured to a #2 Yellow Pine test buck with seven #8 x 3" wood screws, one 3" from each corner and on 16" spacing around the arch.

Overall Area: 58.72 ft²

Test Results: The results are tabulated as follows:

	<u>Indicator Number</u>			Net
	1	2	3	
Uniform Load Deflection per ASTM E 330 (Deflections were taken on the door)				
36.2 psf (positive) (load held for 30 seconds)	0.35"	0.71"	0.43"	0.32"
45.7 psf (negative) (load held for 27 seconds)	0.26"	0.67"	0.41"	0.34"

	<u>Indicator Number</u>			Net
	4	5	6	
Uniform Load Deflection per ASTM E 330 (Deflections were taken on the transom sill)				
36.2 psf (positive) (load held for 30 seconds)	0.09"	0.16"	0.09"	0.07"
45.7 psf (negative) (load held for 27 seconds)	0.16"	0.22"	0.13"	0.08"

	<u>Indicator Number</u>			Net
	1	2	3	
Uniform Load Structural per ASTM E 330 (Permanent sets were taken on the door)				
54.3 psf (positive) (load held for 10 seconds)	0.08"	0.08"	0.06"	0.01"
68.6 psf (negative) (load held for 10 seconds)	0.05"	0.05"	0.04"	<0.01"

	<u>Indicator Number</u>			Net
	4	5	6	
Uniform Load Structural per ASTM E 330 (Permanent sets were taken on the door)				
54.3 psf (positive) (load held for 10 seconds)	0.02"	0.03"	<0.01"	0.02"
68.6 psf (negative) (load held for 10 seconds)	0.02"	0.02"	0.01"	<0.01"

Note: See ATI Sketch #1 for indicator locations

Detailed drawings, representative samples of the test specimen, and a copy of this report will be retained by ATI for a period of four years from the original test date. This report is the exclusive property of the client so named herein and is applicable to the sample tested. Results obtained are tested values and do not constitute an opinion or endorsement by this laboratory. This report may not be reproduced, except in full, without approval of Architectural Testing, Inc.

For ARCHITECTURAL TESTING, INC.

James Sturdevant
Technician

Joseph A. Reed, P.E.
Director - Engineering and Product Testing

JSL:ajl/cmd

Attachments (pages):

- Appendix-A: Sketch (1)
- Appendix-B: Drawings (7)

Revision Log

<u>Rev. #</u>	<u>Date</u>	<u>Page(s)</u>	<u>Revision(s)</u>
0	08/18/06	N/A	Original report issue

APPENDIX A

Sketch

REV	DATE	DESCRIPTION	BY

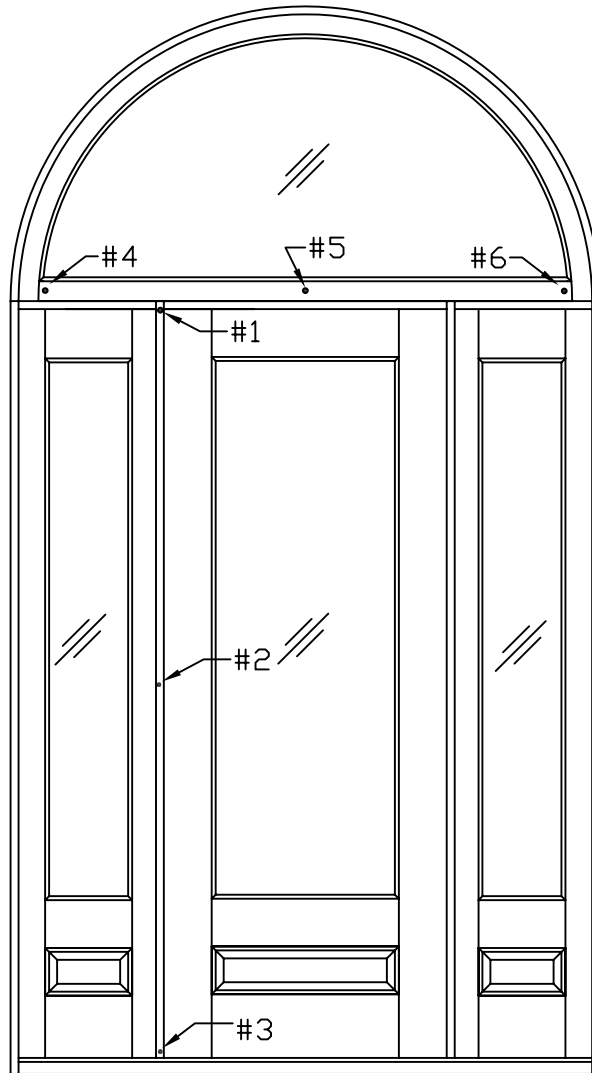

PROJECT NO.
64142.01
801-44

PROJECT NAME: INSWING HARDWOOD DOOR
CLIENT: GLASS CRAFT



DRAWING

INDICATOR SKETCH

DWG. BY:
BWM
DATE:
08/18/06

SHEET
1 OF
1

APPENDIX B

Drawings

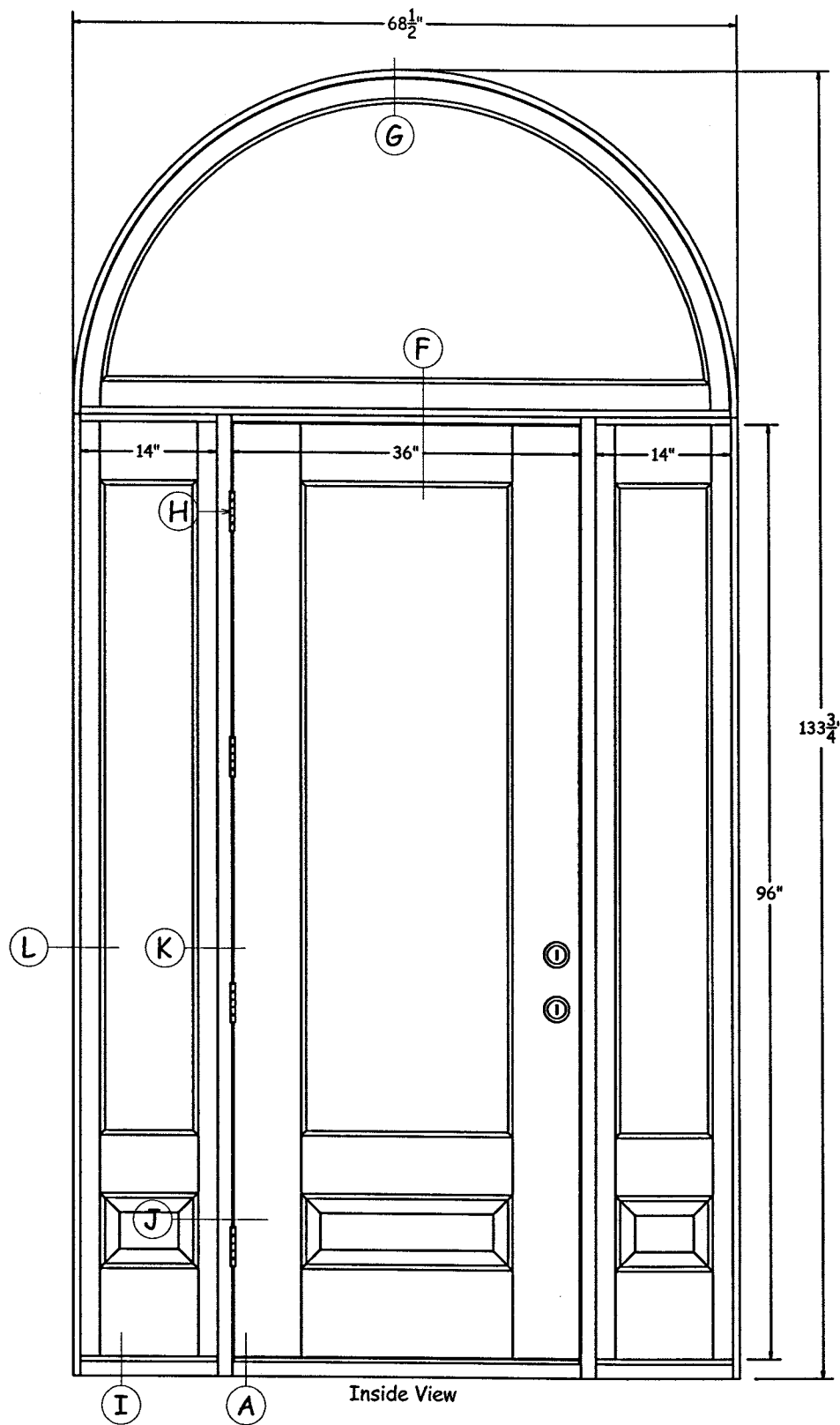

Architectural Testing

Test sample complies with these details.
Deviations are noted.

Glass*Craft
Door Company

Houston Texas 77043 (713)-690-8282

Report# 64141, 64142
Date 4/18/06 Tech JS

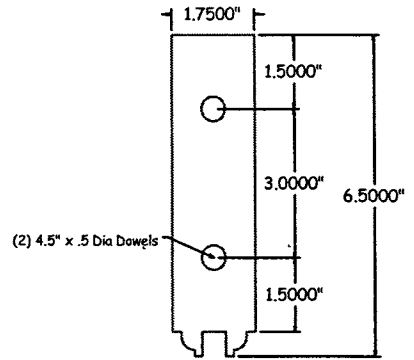
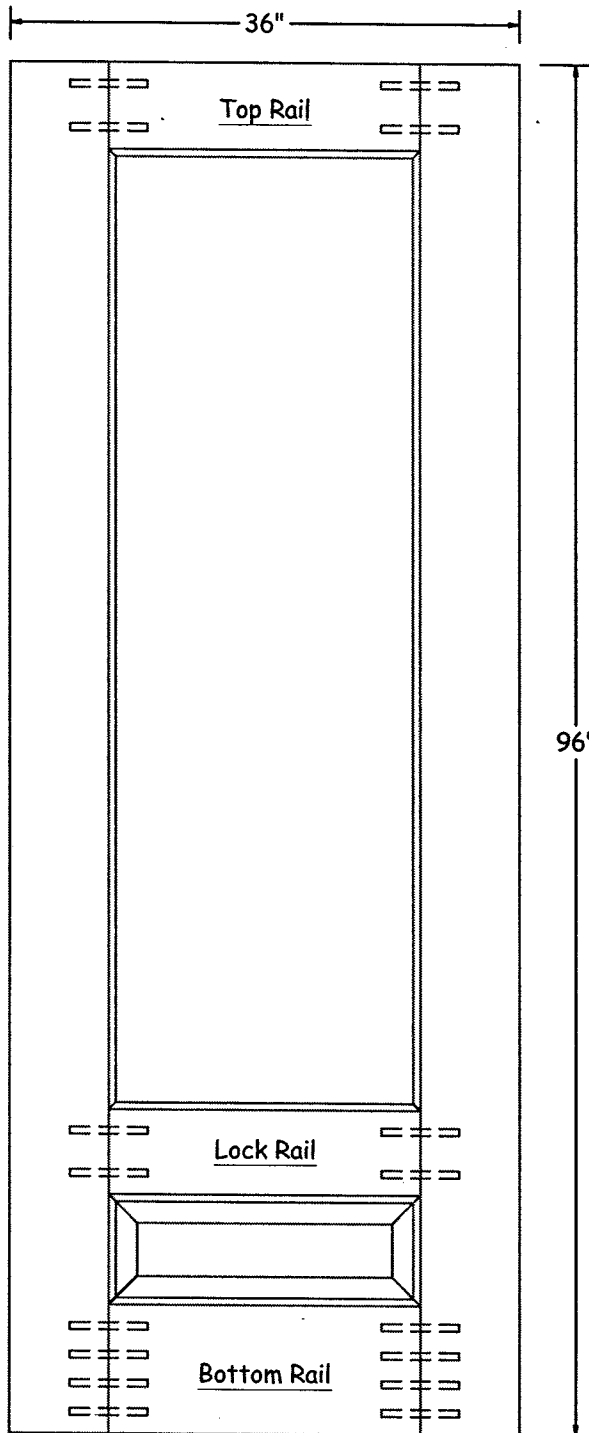
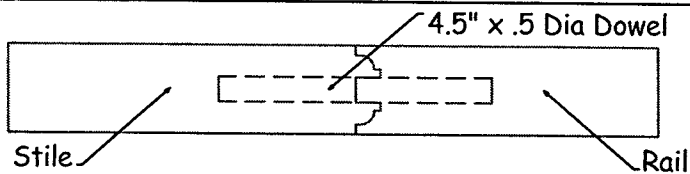

Top Rail

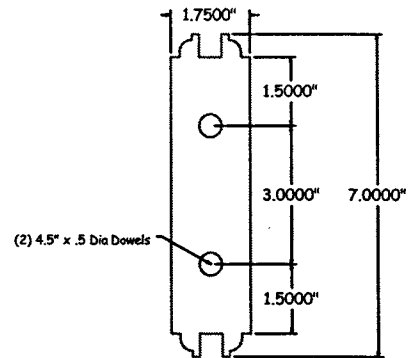

Lock Rail

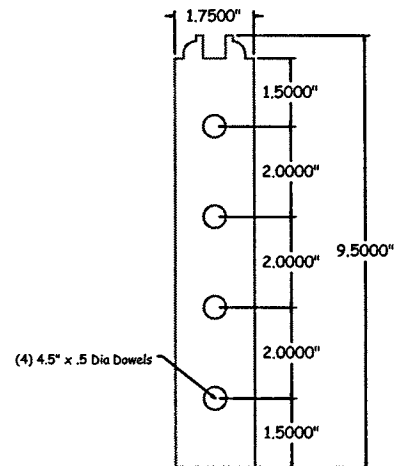

Bottom Rail



Architectural Testing

Test sample complies with these details.
Deviations are noted.

Report# 64137, 64138, 64141, 64142

Date 7/31/06 Tech JS

Glass*Craft
Door Company
Houston Texas 77043 (713)-690-8282

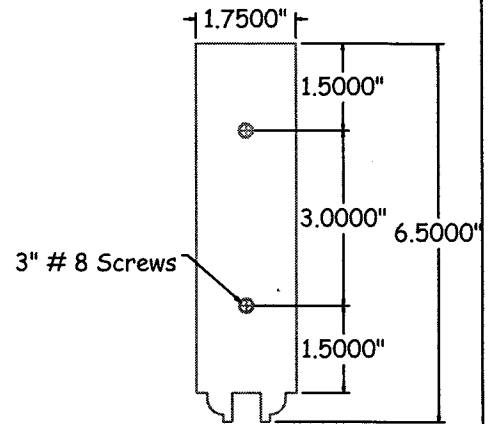
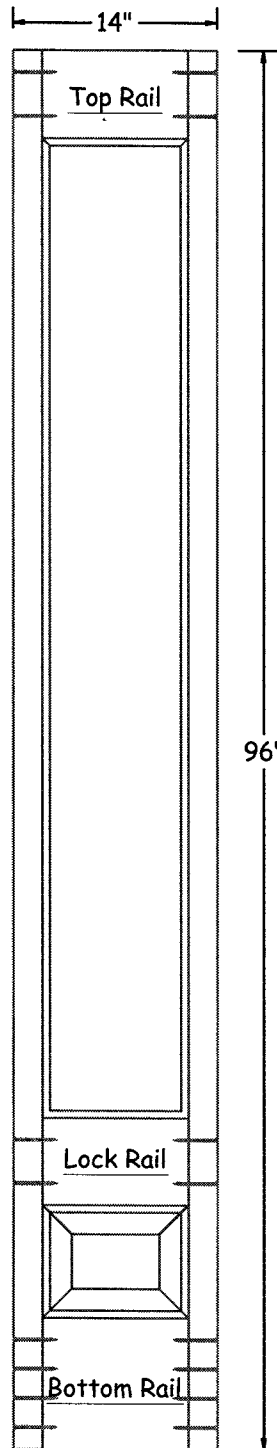
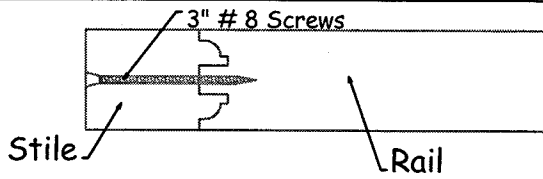

Top Rail

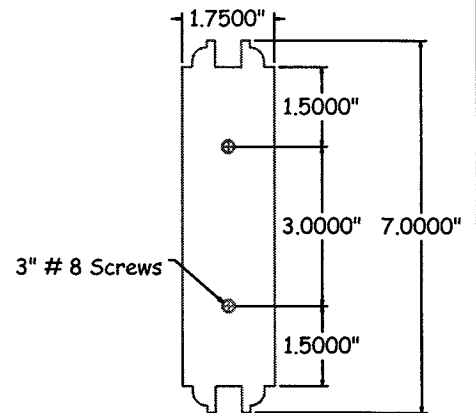

Lock Rail

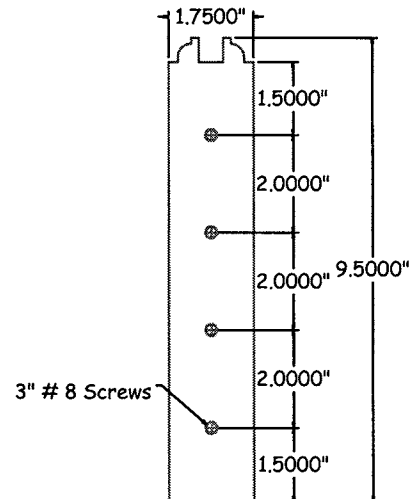

Bottom Rail



Architectural Testing

Test sample complies with these details.
Deviations are noted.

Glass*Craft
Door Company
Houston Texas 77043 (713)-690-8282

Report# 64141, 64142
Date 7/31/06 Tech JS

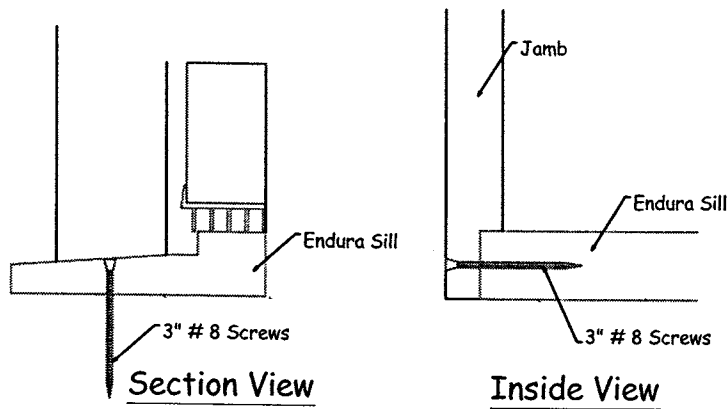

A Threshold

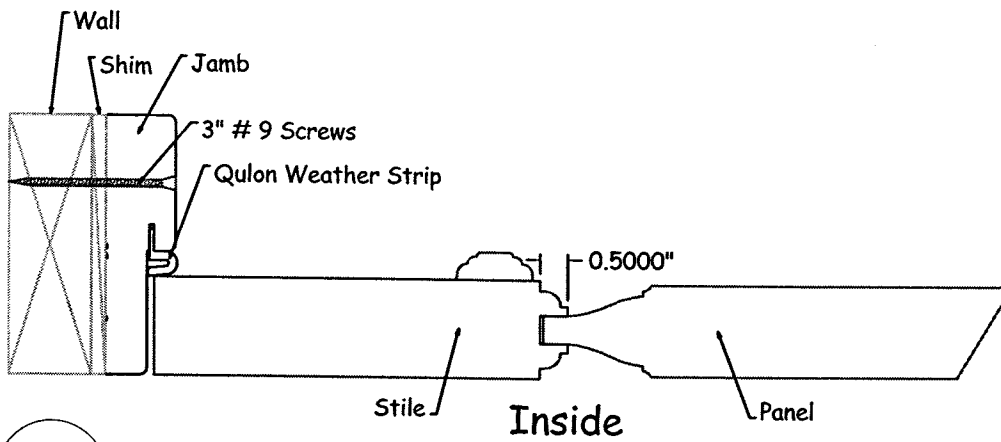

B Panel

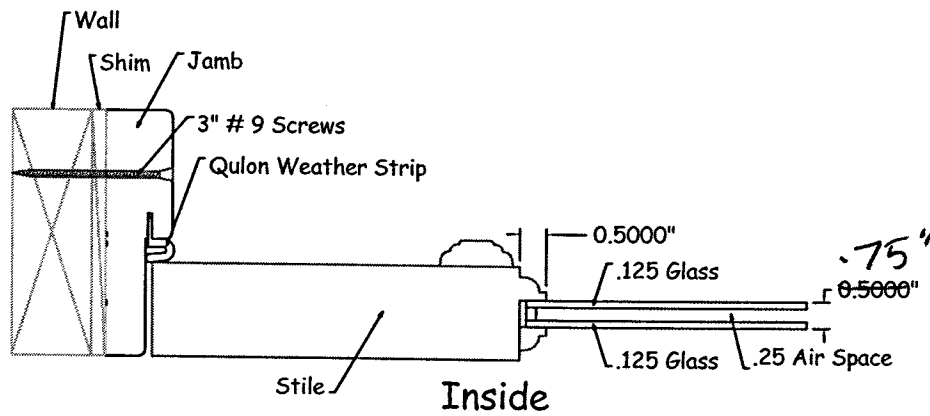

C Glass



Architectural Testing

Test sample complies with these details.
Deviations are noted.

Glass*Craft
Door Company

Houston Texas 77043 (713)-690-8282

Report # 64137, 64138, 64141, 64142

Date 2/31/06 Tech JS

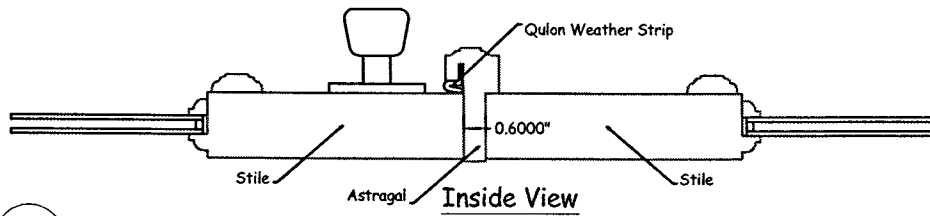

D Astragal

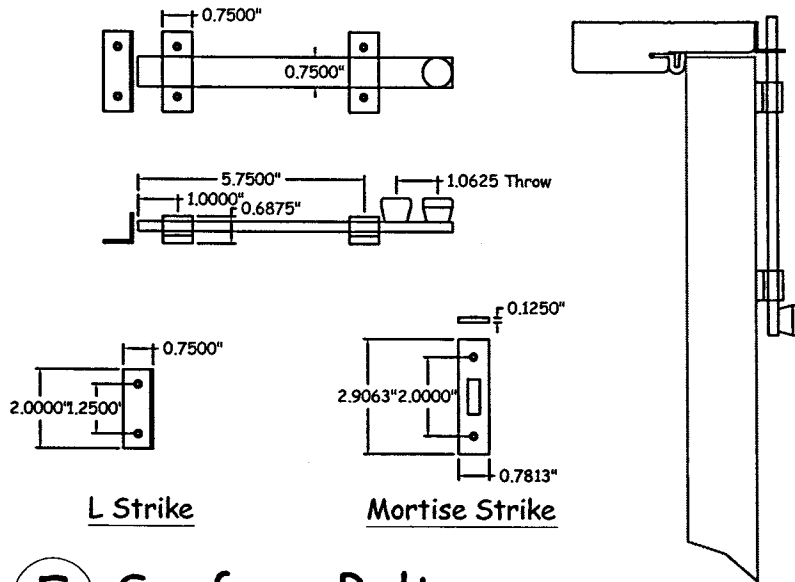

E Surface Bolt

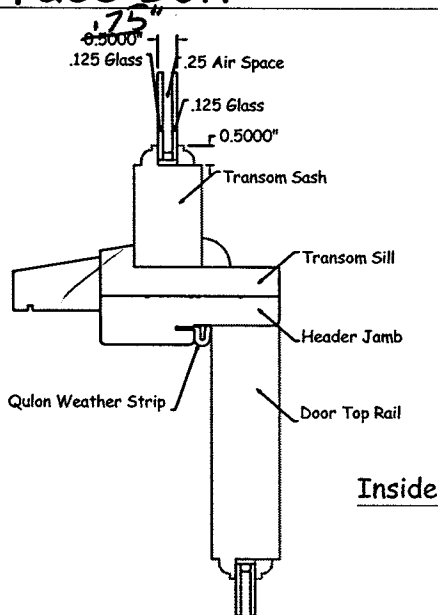

F Header-Sill

Architectural Testing

Test sample complies with these details.
Deviations are noted.

Report# 64137, 64138, 64141, 64142
Date 7/31/06 Tech JS

Glass*Craft
Door Company
Houston Texas 77043 (713)-690-8282

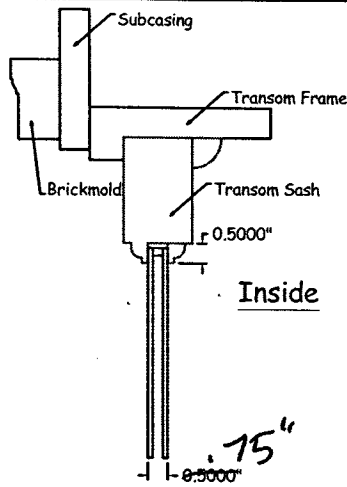

G Transom Head

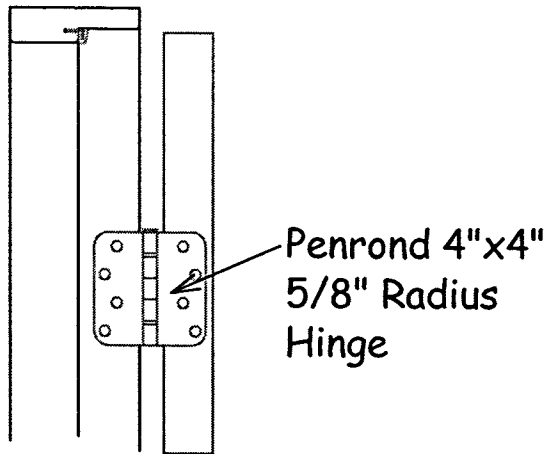

H Door Hinge

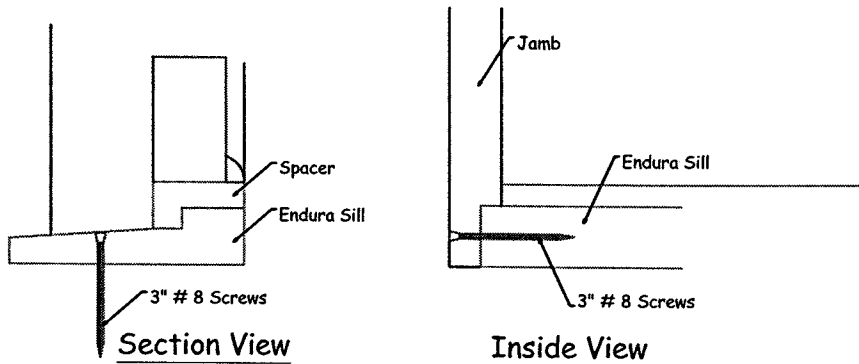

I Threshold @ Sidelite



Architectural Testing

Test sample complies with these details.
Deviations are noted.

Report# 64141, 64142, 64137, 64138

Date 7/21/06 Tech JS

Glass*Craft
Door Company

Houston Texas 77043 (713)-690-8282

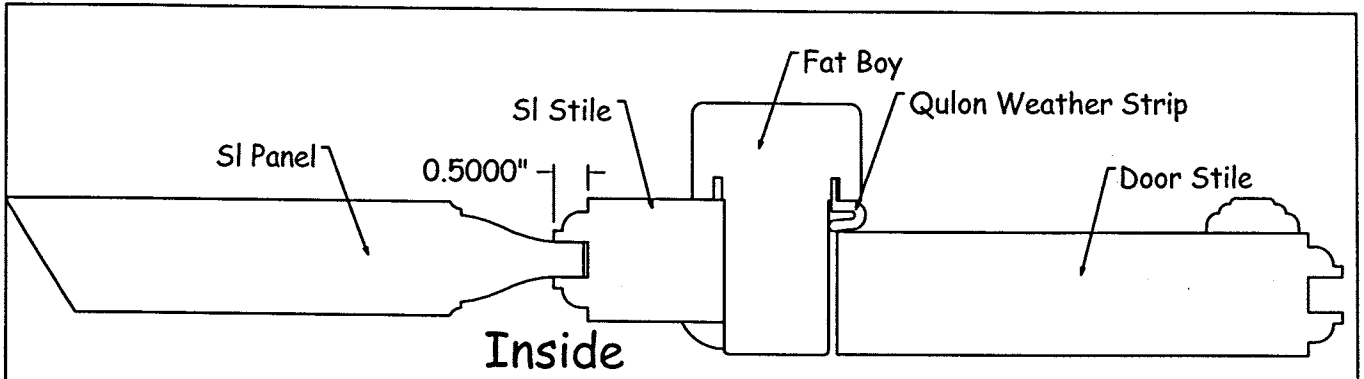

J Sidelite Panel

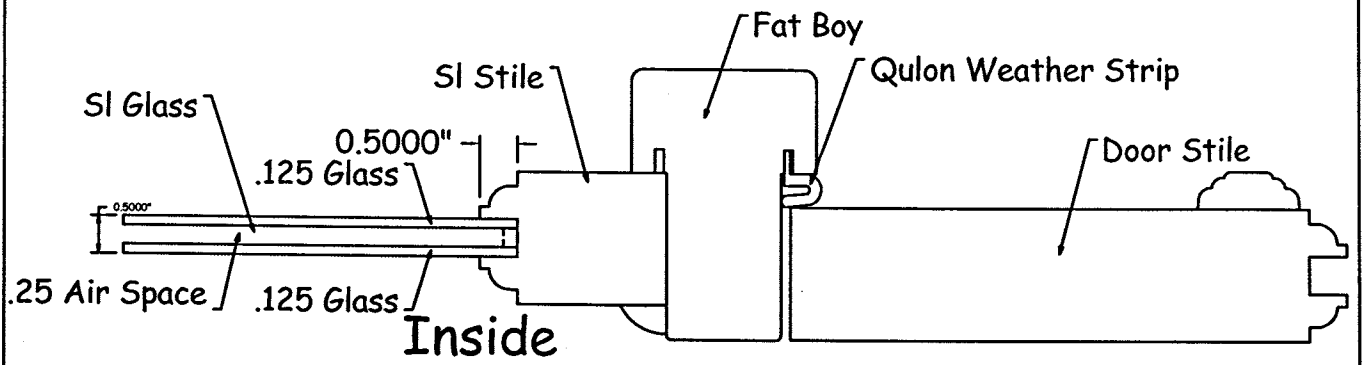

K Sidelite Panel

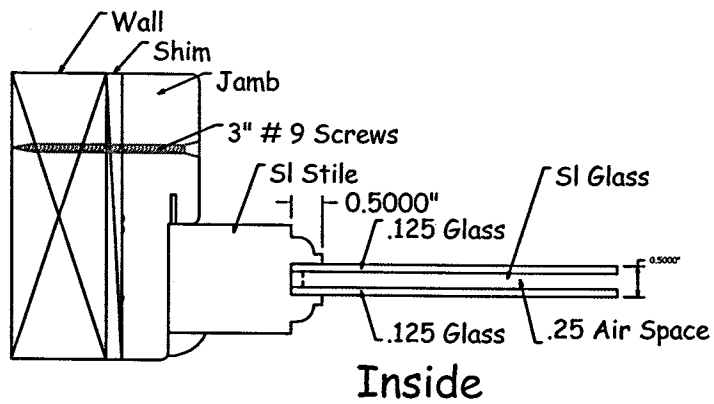

L Sidelite



Architectural Testing

Test sample complies with these details.
Deviations are noted.

Report# 64141, 64142
Date 4/8/06 Tech JS

Glass*Craft
Door Company
Houston Texas 77043 (713)-690-8282